



# PERGOLAS

EDITION / EN

# Table of contents

<b>PERGOLAS .....</b>	<b>4</b>
Sunbreaker 500 .....	6
Sunbreaker 500R .....	8
Sunbreaker 400 .....	10
Sunbreaker 400R .....	12
Sunbreaker 400 H .....	14
SLIDE .....	16
Sunbreaker 400 MD .....	18
Solid .....	20

## Contacts

 7900 Szigetvár, Dencsházai út 2.

 +36 70 943 3447

 [info@skm-protect.hu](mailto:info@skm-protect.hu)









**SYSTEM  
PERGOLA**

# PERGOLA SUNBREAKER 500



Colour	RAL
Electric drive	yes
Maximum projection	7.0 m
Maximum width	5.0 m
Water drainage system	yes

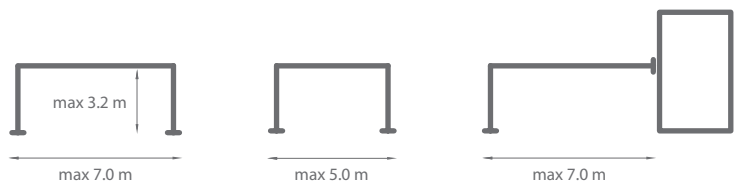

Standard construction colours:

- RAL 9016 mat
- FSM 71319
- RAL 7016 mat

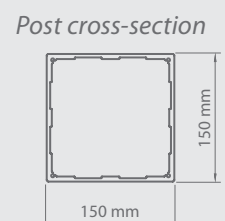
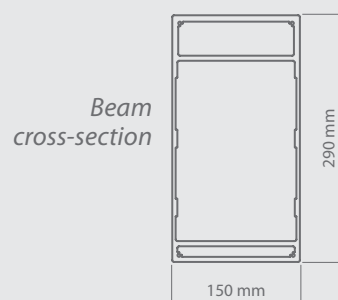
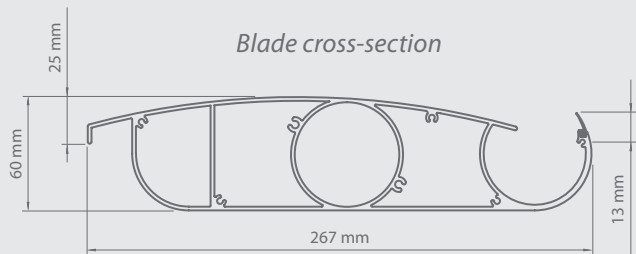





**Properties:**

- *Extruded aluminium construction with steel elements*
- *Water drainage system integrated with the construction*
- *Sun and waterproof system*
- *Construction and roofing painted in any RAL colour (optional)*
- *Roofing made from rotating slats*
- *Maximum dimensions of single module: 5.0 m width and 7.0 m projection*
- *Minimum dimensions of single module: 2.0 m width and 2.0 m projection*
- *Possibility of modular connection*
- *Possibility of wall-mounted and free-standing version*
- *Possibility of using sliding wall system "SLIDE" up to 2.8m high*
- *Construction in accordance with EN 1090 and EN 13659*
- *Optional LED lighting on perimeter of pergola or light points in blades*
- *Possibility of using weather automation*

# PERGOLA SUNBREAKER 500R



Colour	RAL
Electric drive	yes
Maximum projection	7.0 m
Maximum width	5.0 m
Beam height	290 mm + 150 mm blades opening
Water drainage system	yes (without outflows)

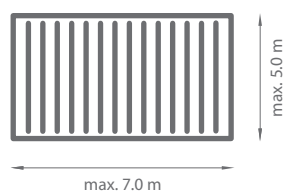

Standard construction colours:

- RAL 9016 mat
- FSM 71319
- RAL 7016 mat

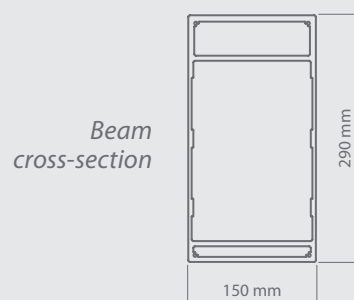
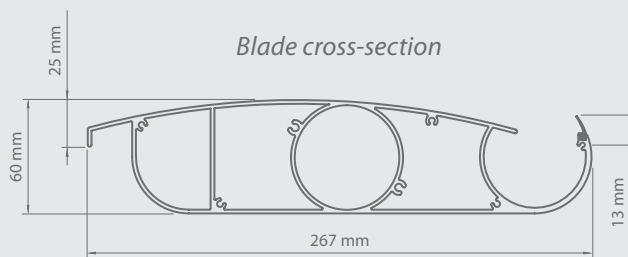
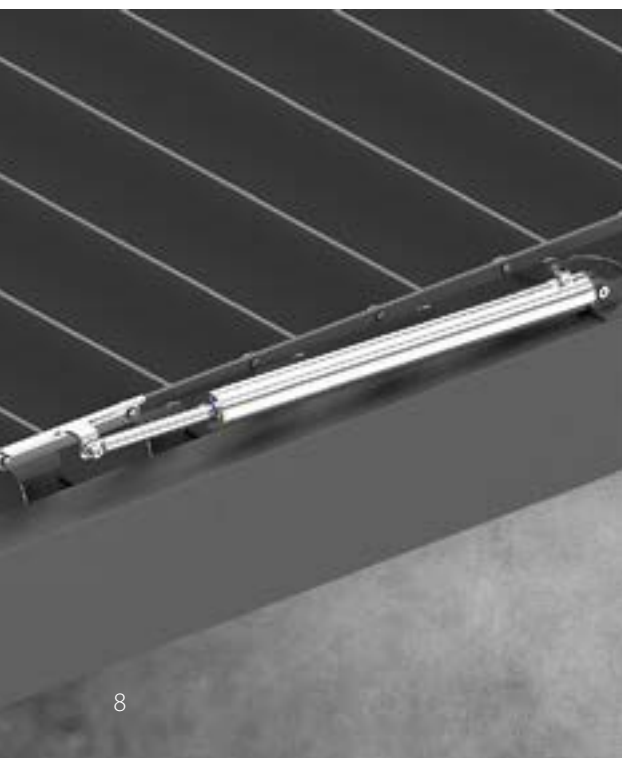





**Properties:**

- *The structure made of extruded aluminum profiles and steel elements*
- *The structure is equipped with a water drainage system (gutters without outflows)*
- *Sun protection and rain protection system*
- *Maximum dimensions: 5.0 m wide, projection 7.0 m*
- *Drain points selected individually*
- *Optional LED lighting around the pergola or light points in the blades*
- *Possibility of using weather automation*
- *6th class of wind resistance*
- *Through-anchoring of beams*



# PERGOLA SUNBREAKER 400



Colour	RAL
Electric drive	yes
Maximum projection	7.0 m
Maximum width	4.0 m
Water drainage system	yes

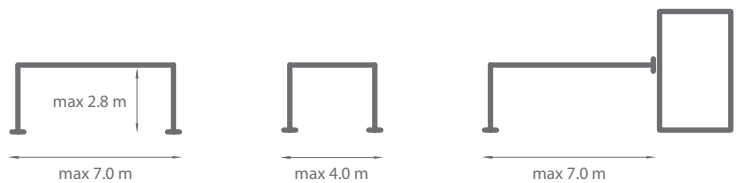

Standard construction colours:

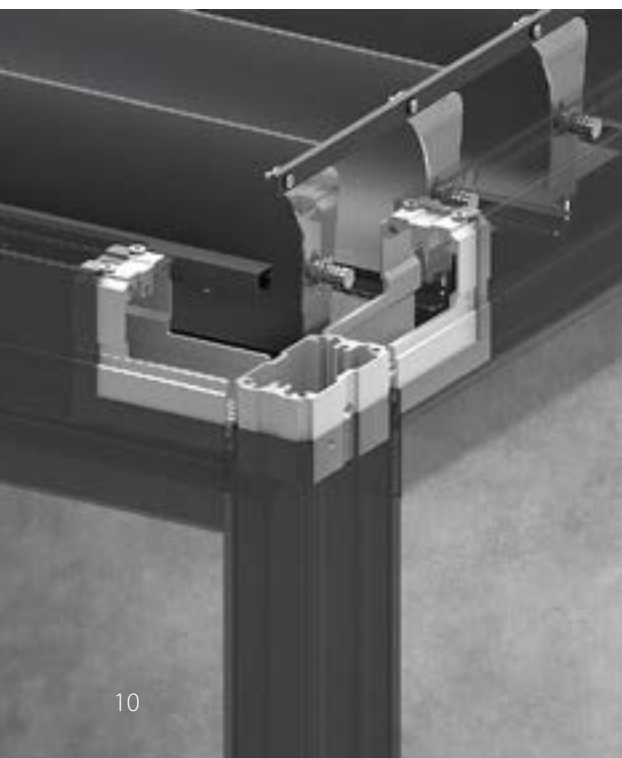

*Blade cross-section*

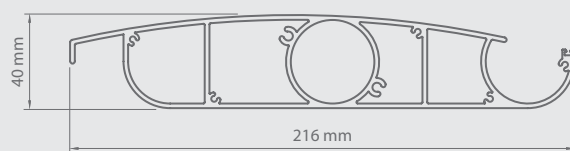

*Beam cross-section*

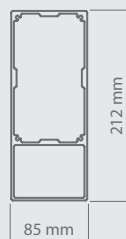

*Post cross-section*

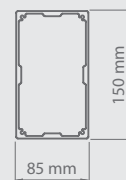



**Properties:**

- *Extruded aluminium construction with steel elements*
- *Water drainage system integrated with the construction*
- *Sun and waterproof system*
- *Possibility of using weather automation*
- *Construction and roofing painted in any RAL colour (optional)*
- *Roofing made from rotating slats*
- *Maximum dimensions of single module: 4.0 m width and 7.0 m projection*
- *Minimum dimensions of single module: 1.4 m width and 1.4 m projection*
- *Free-standing and wall-mounted version*
- *Construction in accordance with PN-EN 1090 and PN-EN 13659*
- *Additional chamber in the beam allows to use an invisible overflow system between the gutters (option with 4 gutters)*
- *Optional LED lighting on perimeter of pergola or light points in blades*



# PERGOLA SUNBREAKER 400R

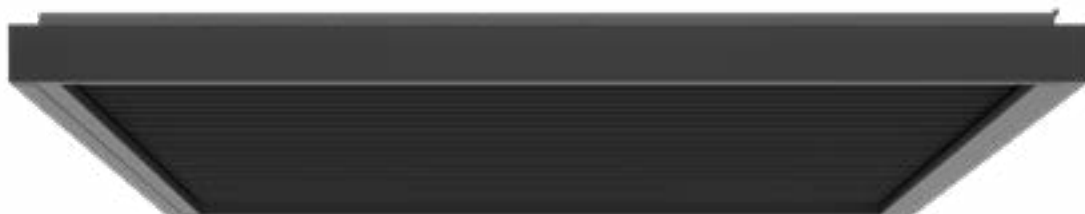

Colour	<b>RAL</b>
Electric drive	<b>yes</b>
Maximum projection	<b>7.0 m</b>
Maximum width	<b>4.0 m</b>
Beam height	<b>290 mm + 150 mm blades opening</b>
Water drainage system	<b>yes (without outflows)</b>

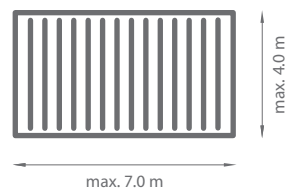

Standard construction colours:

- RAL 9016 mat
- FSM 71319
- RAL 7016 mat

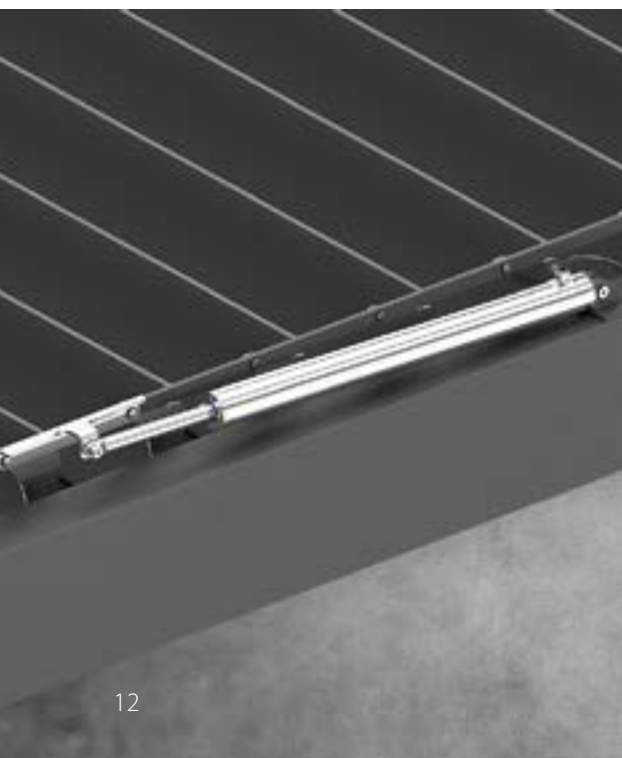

*Blade cross-section*

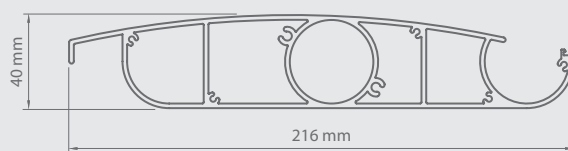

*Beam cross-section*

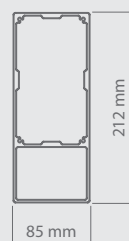



**Properties:**

- *The structure made of extruded aluminum profiles and steel elements*
- *The structure is equipped with a water drainage system (gutters without outflows)*
- *Sun protection and rain protection system*
- *Maximum dimensions: 4.0 m wide, projection 7.0 m*
- *Drain points selected individually*
- *Optional LED lighting around the pergola or light points in the blades*
- *Possibility of using weather automation*
- *6th class of wind resistance*
- *Wall brackets included*



# PERGOLA

# SUNBREAKER 400H



Colour	RAL
Electric drive	yes
Maximum projection	7.0 m
Maximum width	4.0 m
Water drainage system	yes



Standard construction colours:

- RAL 9016 mat
- FSM 71319
- RAL 7016 mat



*Blade cross-section*

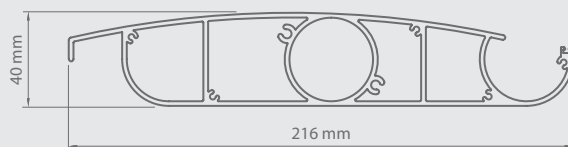

*Beam cross-section*

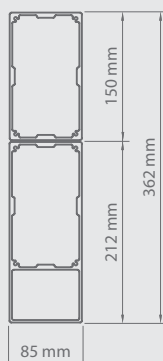

*Post cross-section*

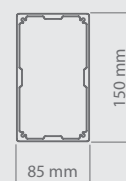



**Properties:**

- *Extruded aluminium construction with steel elements*
- *Water drainage system integrated with the construction*
- *Sun and waterproof system*
- *Possibility of using weather automation*
- *Construction and roofing painted in any RAL colour (optional)*
- *Roofing made from rotating slats*
- *Maximum dimensions of single module: 4.0 m width and 7.0 m projection*
- *Minimum dimensions of single module: 1.4 m width and 1.4 m projection*
- *Construction in accordance with PN-EN 1090 and PN-EN 13659*
- *Additional chamber in the beam allows to use an invisible overflow system between the gutters (option with 4 gutters)*
- *Optional LED lighting on perimeter of pergola or light points in blades*
- *Additional beam hiding the motor*



# SYSTEM SLIDE

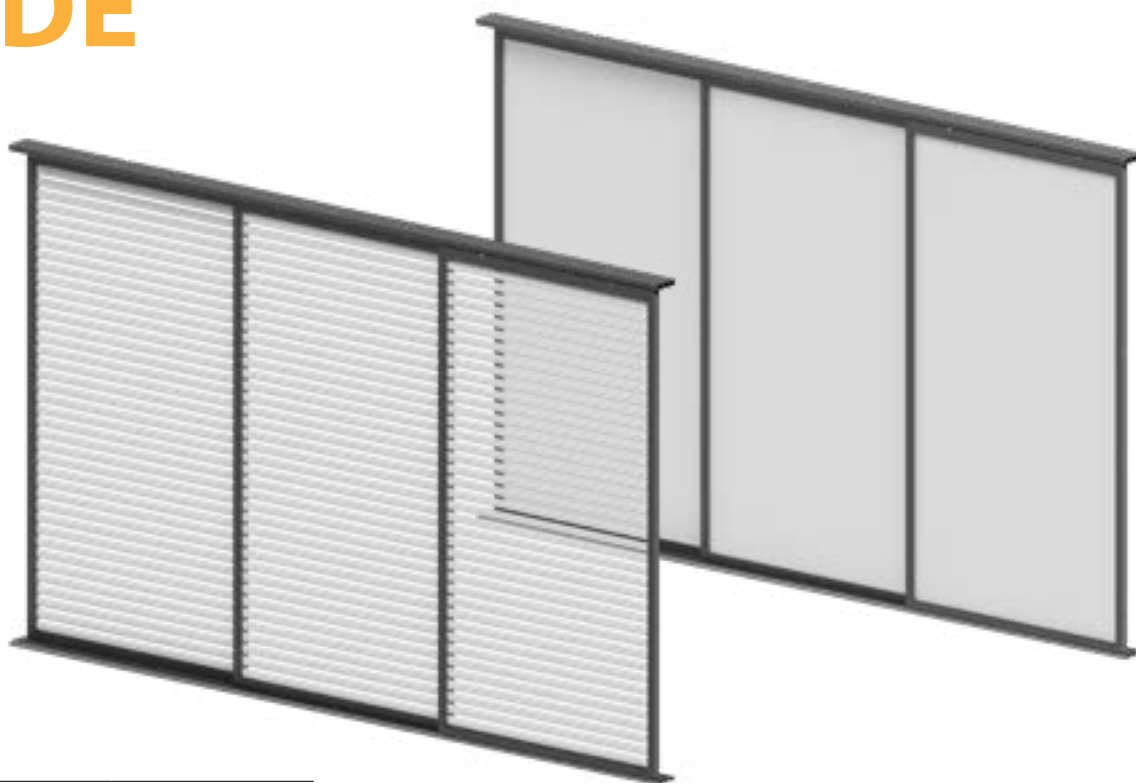

Colour	RAL
Max width of single module	1.38 m
Max height of single module	2.80 m
External use	yes
Cover	fixed blades Serge 1% fabric Serge 600 fabric

Standard construction colours:

- RAL 9016 mat
- FSM 71319
- RAL 7016 mat

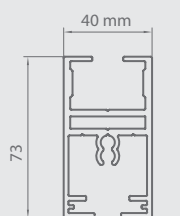
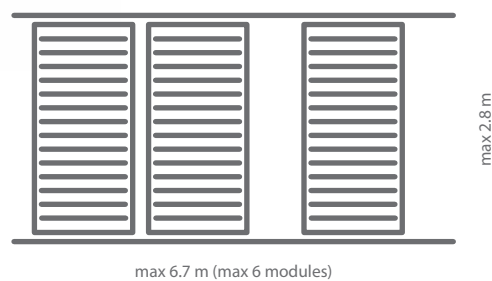

Upper frame cross-section

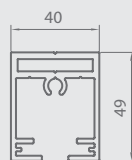

Bottom and side frame cross-section

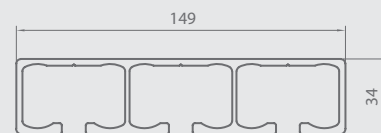

Upper guide rail cross-section

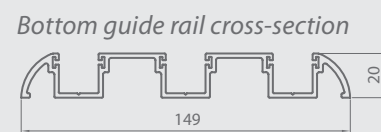

Bottom guide rail cross-section

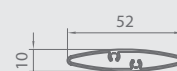

Blade cross-section



**Properties:**

- *Extruded aluminium construction*
- *Construction painted in any RAL colour (optional)*
- *Trolley based sliding system*
- *System equipped with a 3-track guide rail*
- *Wind resistance class 6*
- *Fixed blade angle*
- *Mixed colours available (blades + frame)*
- *SLIDE system tested in IFT Rosenheim*
- *SLIDE system is dedicated to Pergola SB500 (maximum height of 2.8m)*



# PERGOLA

# SUNBREAKER 400MD



Colour	<b>RAL</b>
Electric drive	<b>yes</b>
Maximum projection	<b>7.03 m</b>
Maximum width	<b>4.0 m</b>
Water drainage system	<b>yes</b>

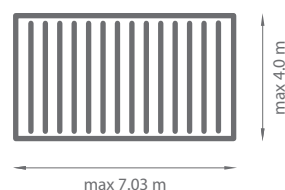

Standard construction colours:

- RAL 9016 mat     FSM 71319     RAL 7016 mat



*Blade cross-section*

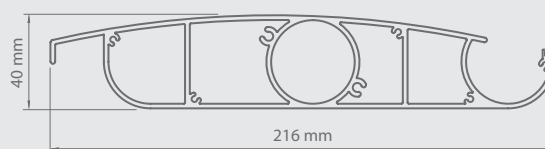

*Guide rail cross-section*



**Properties:**

- *Extruded aluminium construction*
- *Construction and roofing painted in any RAL colour (optional)*
- *Supporting subconstruction required*
- *Maximum projection 7.03 m*
- *The highest wind resistance class according to EN 13659*
- *Motor must be mounted to the supporting structure (partially outside the product outline)*
- *Gutters and sealing blades - optional*
- *Rain water pipes not included*



# PERGOLA SOLID



Colour	<b>RAL</b>
Electric drive	<b>yes</b>
Maximum projection	<b>7.0 m</b>
Maximum width	<b>4.0 m</b>
Tilt angle	<b>5°-10°</b>
Cover	<b>PVC fabric dedicated for Solid system</b>

Standard construction colours:

- RAL 9016 mat
- FSM 71319
- RAL 7016 mat

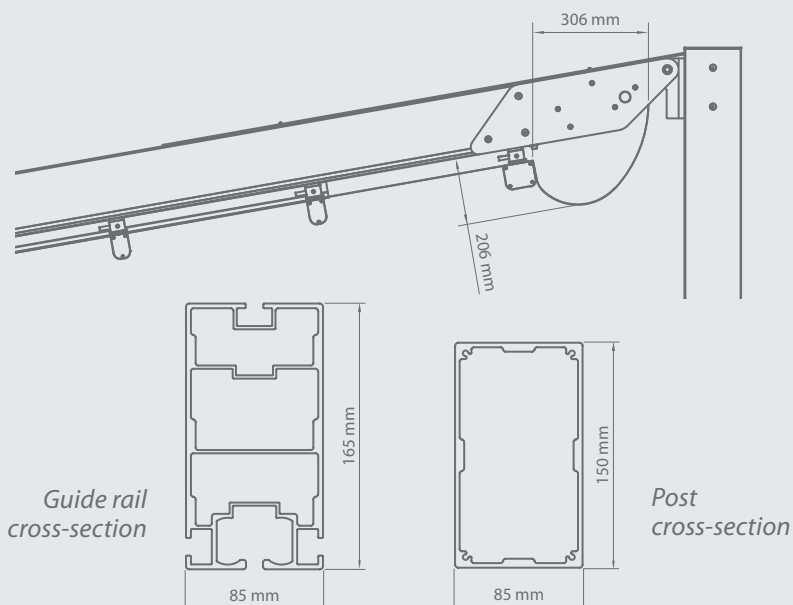
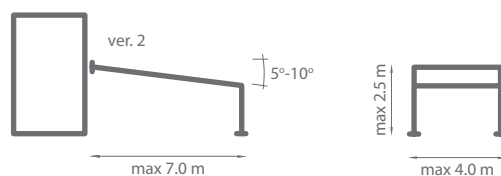
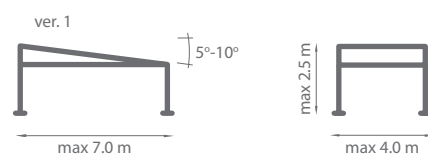



**Properties:**

- *Extruded aluminium construction with steel elements*
- *Water drainage system integrated with the construction*
- *Sun and waterproof system*
- *Movable roofing operated electrically*
- *Possibility of using weather automation*
- *Optional LED lighting application in the movable beams*
- *Free-standing and wall-mounted version*
- *Construction painted in any RAL colour (optional)*
- *Minimum size of one module: width 1.5m, projection 2.0m*
- *Maximum size of one module width 4.0m, projection 7.0m*
- *Possibility of modular connection*
- *Construction in accordance with EN 1090 and EN 13561*



